



VTA's BART Silicon Valley Phase II Extension Project

Santa Clara
Community Working Group Meeting

May 16th, 2024

Agenda

- Welcome & Introduction
- Transit-Oriented Communities Grant Update
- Phase II Update
- Santa Clara Design Review Committee Recap
- Early Construction Activities
- Community Engagement
- CWG Member Report Out
- Next Steps

Santa Clara CWG Members



- Alden Smith, Holland Partner Group
- **Ana Vargas-Smith**, *Reclaiming Our Downtown*
- David Cajigas, *Santa Clara University*
- Grace Davis, *SCU Service & Social Justice (SCCAP)*
- Jack Morash, *South Bay Historic Railroad Society*
- John Urban, *Newhall Neighborhood Association*
- Jonathon Evans, *Old Quad Residents Association*
- Ron Miller, *Bellarmino College Preparatory*
- Ryan Morfin, *San José Earthquakes*
- Todd Trekell, *Hunter Partners*
- *Vacant*, *Silicon Valley Central Chamber of Commerce*

Upcoming Meetings



- Upcoming CWG Dates
 - Santa Clara CWG Meeting: September 12, 2024
- VTA Board of Directors vta.org/about/board-and-committees
 - Board of Directors' Meeting: June 6, 2024, 5:30 PM
 - VTA's BSVII Oversight Committee: June 13, 2024, 12:30 PM
 - Board of Directors' Meeting: June 28, 2024, 9:00 AM
 - VTA's BSVII Oversight Committee: July 11, 2024, 12:30 PM
 - Board of Directors' Meeting: August 1, 2024, 5:30 PM
 - VTA's BSVII Oversight Committee: August 8, 2024, 12:30 PM
 - VTA Board of Directors' Meeting: September 5, 2024, 5:30 PM
- Kristen will email alerts for other meetings



Transit-Oriented Communities Grant Update

Melissa Cerezo, VTA

Transit-Oriented Communities Program - Background



2018-2020: VTA TOC Playbooks

- Detailed and implementable recommendations for BART station areas, including addressing displacement of housing and small businesses



2002-2010: Community Design and Transportation Manual

- Design guidelines and capital grant program

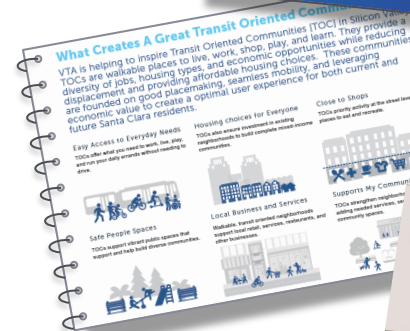

VTA's Transit-Oriented Communities Policy



Goal: Increase transit ridership & reduce vehicle trips through intensive mixed-use, mixed-income development around transit stations and corridors.

Approach:

Leverage VTA-owned sites for TOD



Collaborate to accommodate sustainable growth around transit



CURRENT as of 05/16/24 – FOR DISCUSSION ONLY

Address regional priorities



Source: UC Berkley

Transit-Oriented Communities Program Elements



Grant Partnerships



Regional Leadership



VTA's TOC Grant Program



VTA TOC Working Group



Education and Engagement

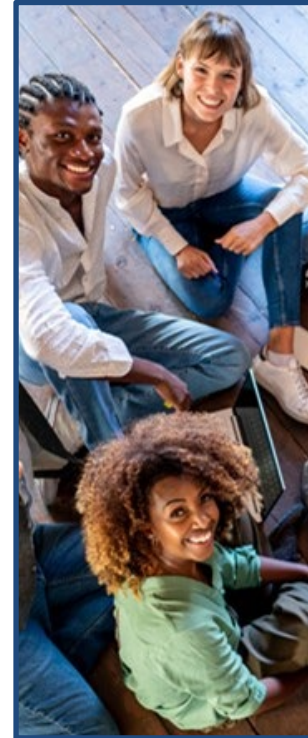







Placemaking and Activation



Transit-Oriented Communities Grant Program Goals



-  **Increase VTA ridership and active transportation modes**
-  **Advance equity and mitigate displacement**
-  Advance transit-supportive policy alignment
-  Increase community capacity for housing preservation
-  Empower communities to advocate
-  Overcome barriers to equitable engagement
-  Strengthen community culture and identity

Transit-Oriented Communities Grant Program



\$750,000 in total funding for the following program areas:

Planning & Policy Implementation



Community Resilience



Education & Engagement



Placemaking, Arts, and Activation





Phase II Update

Bernice Alaniz, VTA

FTA/MTC Meetings & Tours



FTA Region IX Meeting & Tour
April 24th, 2024

MTC Walking Tour
April 25th, 2024



Program Schedule



Based on preliminary schedule for planning purposes.



- Submitted Entry into New Starts Engineering (NSE) application to FTA on March 29th
- Met with FTA Administrator, entire Congressional delegation, and senior staff from OMB and Appropriations Committee in Washington, DC
- Review and engagement with FTA's Financial Management Oversight Consultant (FMOC) anticipated
- Regular meetings and reviews with FTA's Project Management Oversight Consultant (PMOC) continue
- Ongoing preparation for Full Funding Grant Application (FFGA) request

Path to FTA Full Funding Grant Agreement

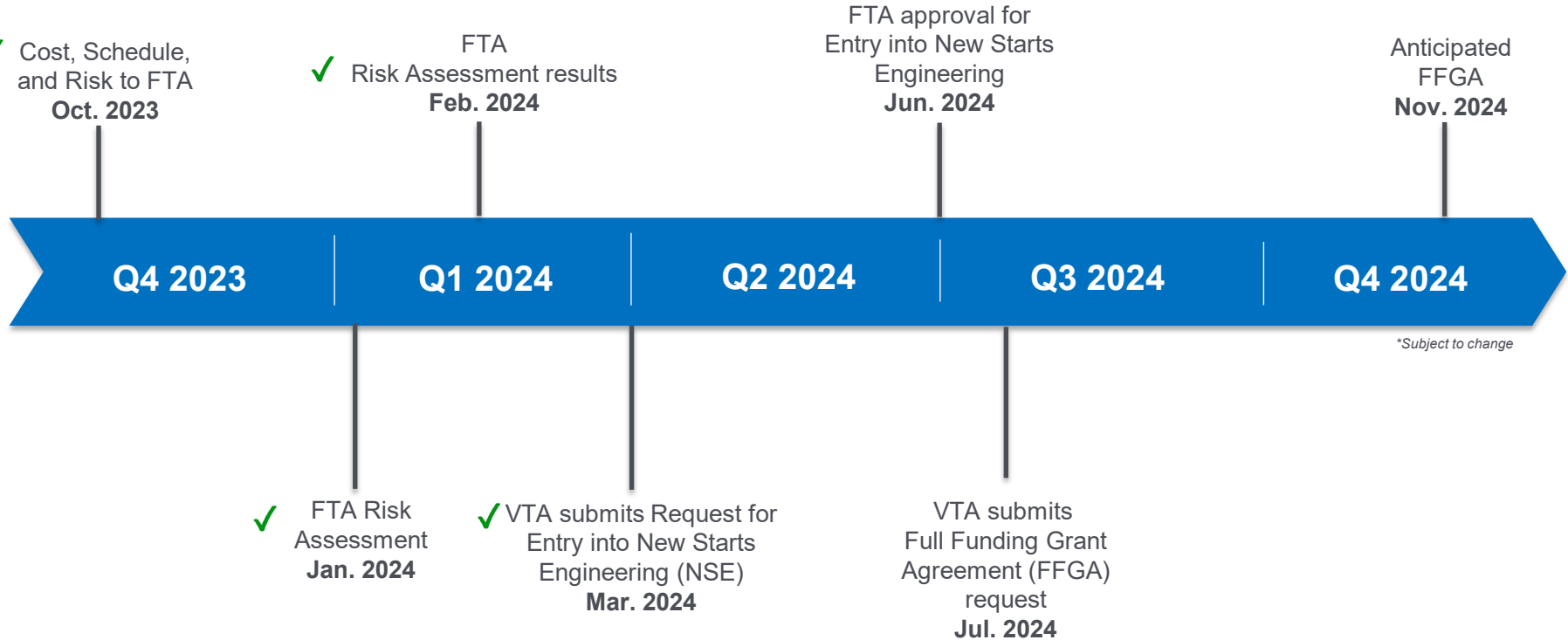

**Subject to change*

NSE Application: Cost Estimate & Funding Plan



FTA Standard Cost Category	Estimate (YOE)
10 - GUIDEWAY & TRACK ELEMENTS	\$2,900
20 - STATIONS	\$2,037
30 - YARDS, SHOPS	\$352
40 - SITEWORK & SPECIAL CONDITIONS	\$582
50 - SYSTEMS	\$1,409
60 - ROW, LAND, EXIST. IMPROV.	\$241
70 - VEHICLES	\$205
80 - PROFESSIONAL SERVICES	\$2,973
90 - UNALLOCATED CONTINGENCY	\$1,657
100 - FINANCE CHARGES	\$390
TOTAL	\$12,746

Notes:

- Costs are rounded to millions
- Reflects FTA-PMOC feedback, including changes to allocated/unallocated contingencies
- SCC 80 includes VTA, BART, Consultants (PMT, GEC, CM, others), OCIP, Third Parties, Legal, CP2 Design, IT, Office leases and other supporting costs.

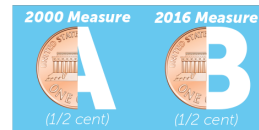
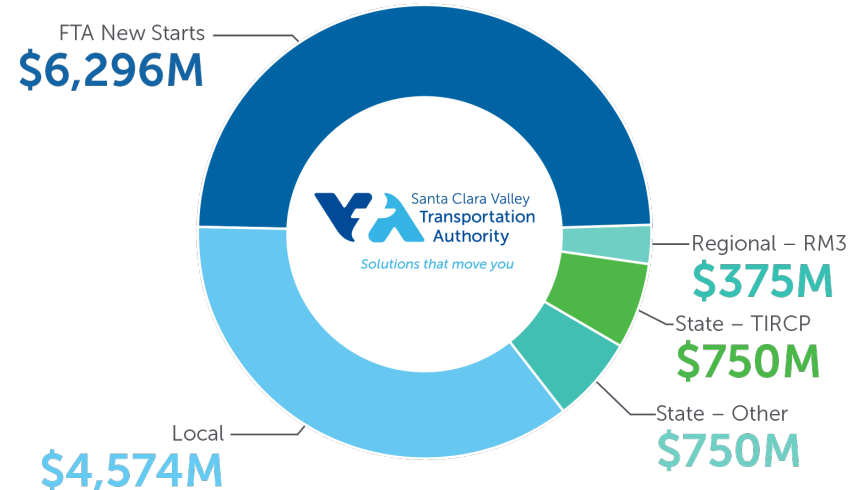

Subject to change pending review with FTA and their Financial Management Oversight Consultant (FMOC)



- **Federal Transit Administration (FTA) announced that \$500 million is officially in the Federal FY24 budget for this project**
- The next six months are very critical for VTA in securing the Federal funding
- Raising project need, benefits, and visibility from a County, State, and Federal level is critical during this period
- Our Congressional Delegation needs to hear about the tremendous support for this Project from all levels of the community – including residents, community stakeholders, businesses, and elected officials
- The project has had strong local backing since 2000 and VTA is here to deliver it

Project Support and Messaging



2024 is Our Year – Tremendous Federal, State, and Local Financial Commitment in the BART Extension Program

- Nearly \$5.8 billion from the state and county is already committed.

Delivering on the Commitment to the 16-mile Program, Completes the Long-term Vision to "Ring the Bay" with Fast, Frequent Rail Transit

- For the typical 50-mile commute in the Bay Area, taking BART will save riders an average of 30 minutes as opposed to driving.

Clean, Green Transit Alternative to Major Congested Commute Corridors

- Reduces traffic congestion and delays by providing a practical environmentally friendly alternative to driving.

Project Support and Messaging



Delivering Equitable Transit Access

- Ensures easier access to jobs, healthcare and all levels of education



Affordable Housing for a Diverse Workforce

- Planning for up to 60 million sq. ft. of new commercial and residential development near station areas.



Sustain and Grow the Silicon Valley Economy

- Every \$1 invested in the project results in \$5 of economic growth
- Expands employment opportunities for two million people in Santa Clara County by providing access to three-and-a-half million Bay Area jobs.



Job Creation

- Upon completion, the project will have generated 75,000 jobs offering substantial direct and indirect employment opportunities.

Call to Action



Contact your congressional delegates to share need for the project



Share project updates with your networks through meetings or newsletters

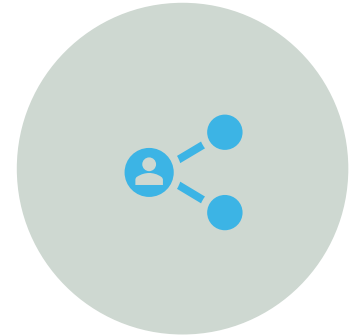

Re-post our project information on your social platforms



VTA Board Referral



VTA Board direction provided at the May 2nd Board Meeting

- Provide written report on the stakeholder requests/concerns related to the 28th Street Little Portugal, Downtown San José, and Diridon Stations
- Perform design updates for
 - Above ground facilities at 28th Street Little Portugal Station
 - Added southern entrance at Downtown San José Station
 - Above ground facilities at Diridon Station
- Provide monthly station design updates to VTA's BART Silicon Valley Phase II Oversight Committee.
- **Community Working Group (CWG) meeting process.**
 - Discuss in-person meetings, dedicated staff/consultant support, and review of project documents prior to their presentation to the VTA Board of Directors

Full Items of Referral can be found listed in the Board Agenda Packet, pg 263-265



Community Working Group Discussion & Poll

Community Working Group Meeting Poll



Would you like to resume in-person CWG meetings? (Select one)

- a) Yes
- b) No

Community Working Group Meeting Poll



If you would like in-person CWG meetings, how often would you like to attend? (Select all that you prefer)

- a) I would commit to meeting in-person for **every meeting**
- b) I would commit to meeting in-person for **every other meeting**
- c) I would commit to meeting in-person for **one meeting each year**
- d) I'd prefer to keep meeting **virtually** on Zoom
- e) I prefer to have an option between in-person & virtual

Community Working Group Meeting Poll



I like the current meeting format with staff facilitation (Select one)

- a) Yes
- b) No

I would prefer a shift in meeting format towards external facilitation (Select one)

- a) Yes
- b) No

Community Working Group Meeting Poll



Would you be interested in a pre-meeting networking time with CWG members, Project staff, and invited presenters? (Select one)

- a) Yes
- b) No

Would you like to review Project documents prior to the presentation at the Board of Directors meeting? (Select one)

- a) Yes
- b) No

Any other feedback to provide on the CWG meetings?



Santa Clara Design Review Committee Recap

Erica Roecks, VTA

DRC Station Design Considerations



Feature Wall Plaza and Bow Truss Canopy



Orchard Pavilion and Extended Canopy





	Summer 2024	Q3 2024	Q4 2024
Community Engagement – Online and in-person engagement	✓		
DRC Member Recap – Provide results from community engagement and next steps		✓	
Further DRC Discussions			✓

- Public engagement of station aesthetic elements planned for Summer 2024.
- Community will have opportunity to provide feedback both online and in person on the aesthetic and design elements discussed within the DRCs.



Early Construction Activities

Erica Roecks, VTA

Initial Activities at West Portal



- Site grading began in May and may produce vibrations and noise during the day.
- Where applicable, BSV is facilitating ongoing construction coordination and updates between contractor and stakeholders.
- CTMP covering this work was brought to Councils and approved in June 2023.

Anticipated Early Construction Work Hours*



Hauling	Construction Activities**
6:00 AM-4:00 PM	6:00 AM-6:00 PM

*Consistent with approved CTMP Early Works Hours

**Construction activities are planned for Monday-Friday; Saturday activities as needed

Overview of What to Expect

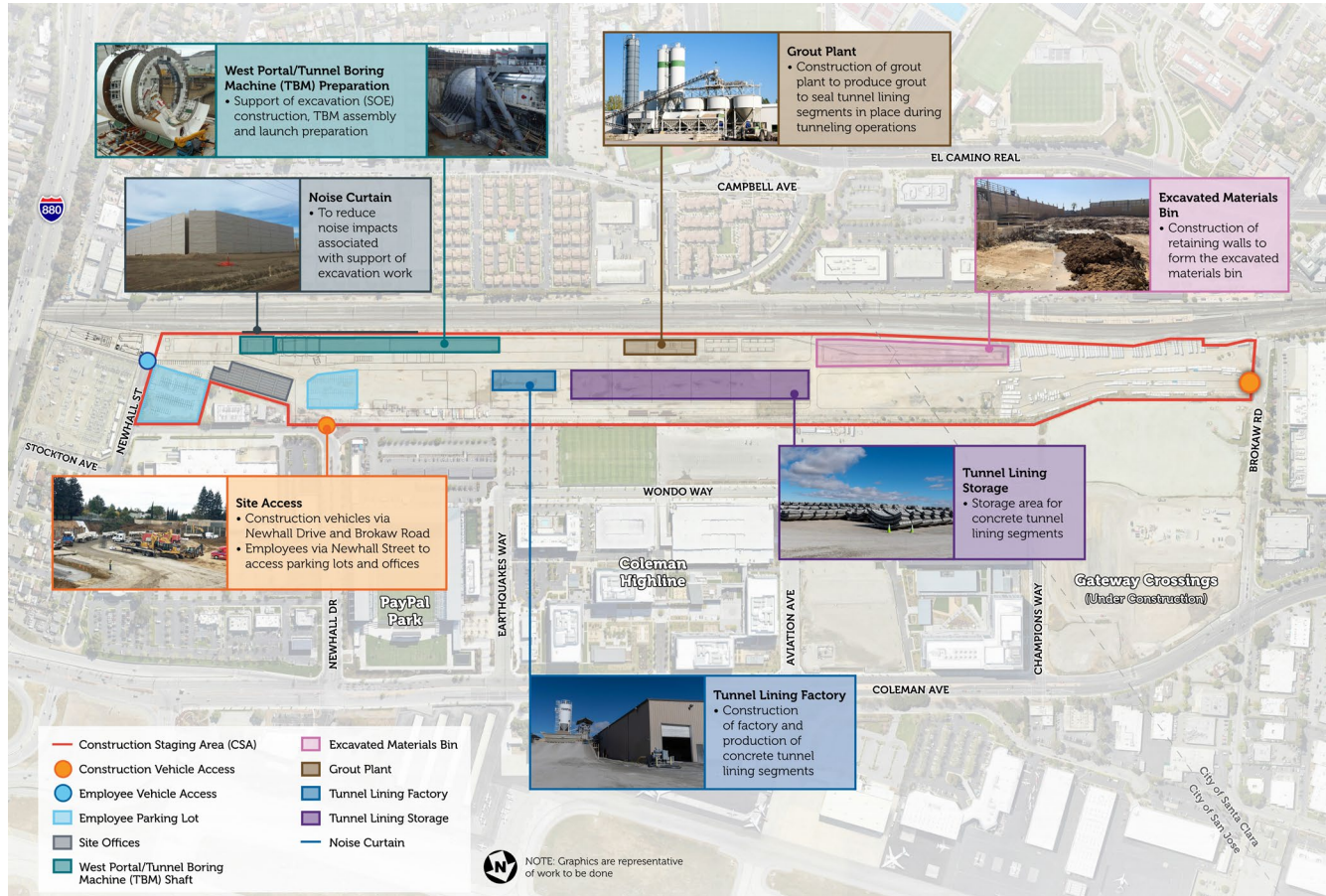

Initial Early Construction Activities



- Civil site work, including:
 1. Wheel Washing, Water Trucks, Street Sweeping
 2. Establishing entry and exit points
 3. Noise & Vibration monitoring
 4. Grading
 5. Fencing, gates and barriers
 6. Security, signage and striping
 7. Temporary offices and parking
 8. Installation of temporary construction utilities
 9. Paving

Fence Removal and Installation



Fence Removal



Fence Installation

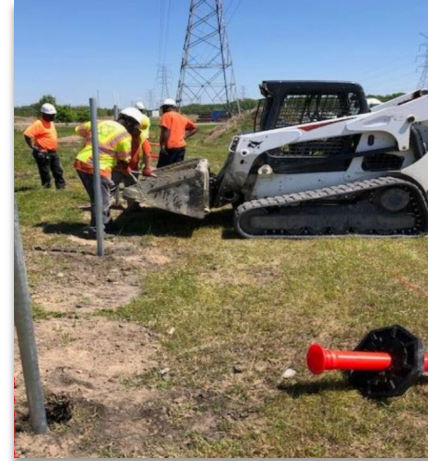

Air Monitoring Action Plan



- Follow measures recommended by Bay Area Air Quality Management District (BAAQMD)
- All off-road Diesel equipment shall have EPA Tier IV Engines – Clean Emissions
- Continuous equipment maintenance and inspection
- General Rule for Dust – No visible dust crossing property line
 - Watering trucks
 - Street sweepers – continuous
 - Vehicles speed on site enforced <15 mph
 - Water applied daily to grading operation and stockpiled soil
 - Posted signage with Hotline phone number
 - Prolonged disturbed soil will be covered with Geo-grid fabric or applied soil binder
 - Moisten/cover haul trucks to prevent dust emissions
 - Suspending dust-intensive activities in high winds



West Portal Construction Screening



Tunnel Boring Machine (TBM) Purchased



- VTA purchased its TBM in November 2023
- The \$76M TBM will be one of the largest machines ever to be built
- Official TBM naming contest closed 4/29, with winning name announced in Summer 2024

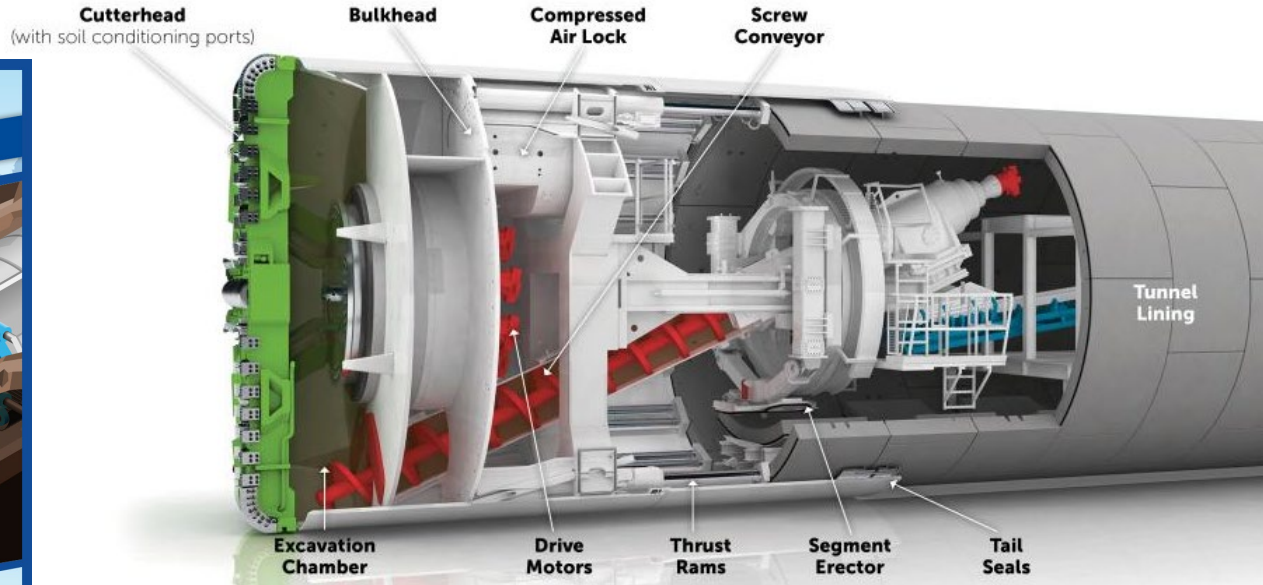



- **WHAT** – summary of construction activity
- **WHERE** – location of construction activity with map
- **WHEN** – include interval of dates and times, include a note if it includes weekend and/or nighttime work
- **WHAT TO EXPECT** – includes information on the activity and impacts (noise, dust, sidewalk closures, parking impacts, bus stop relocations, road detours, etc.)

Example of a Construction Notice



Notice of West Portal Site Work: Week of April 22, 2024

WHAT

- To assist in the beginning of construction work at the West Portal site within the future Newhall Yard & Maintenance Facility, VTA's BART Silicon Valley Phase II (BSVII) project workers will be on site the week of April 22, 2024, to install project equipment comprised of noise, vibration, and air quality monitors.
- The Newhall Neighborhood may witness BSVII project workers within the neighborhood to install project equipment on the Dahlia Loop and De Altura Common, for no more than 2-4 hours at a time.

WHERE

- The West Portal site within the future Newhall Yard & Maintenance Facility.
- Newhall Neighborhood roadways including Dahlia Loop and De Altura Common.

WHEN

- All work will be conducted between 9 am and 5 pm, from Monday, April 22, 2024 – Friday, April 26, 2024.

WHAT TO EXPECT

- BSVII project construction workers to be onsite at variable hours the week of April 22 to install construction equipment.

PROJECT BACKGROUND

VTA's BART Silicon Valley Phase II Extension (Phase II Project) is a six-mile, four-station extension of BART from Berryessa / North San José Station (opened 2020) through downtown San José to the City of Santa Clara. The Phase II Project is planned to include an approx. five-mile subway, three stations with underground platforms (28th Street/ Little Portugal, Downtown San José, and Diridon), one ground-level station (Santa Clara), a train maintenance and storage facility, and additional facilities.



 Area of project equipment installation

Construction is a dynamic process and information is subject to change without notice.



VTA's BART Phase II Hotline
(408) 321-2345
(408) 321-2330 TTY

vta.org/bart
vtabart@vtabsv.com

[@vtabsv](#)
[@vtabsv2](#)
[@vtabsv2](#)



Electronic Distribution

- Email:
 - Distribute via MailChimp to all stakeholders
 - CWG members, City districts, neighborhood associations, targeted stakeholders (e.g., PayPal Park), residents
 - Renotify electronically if changes to start dates
- Post on Project website and Social media
- VTA inputs information in transit apps, 511 & mapping apps
- VTA notifies transit riders for bus stop relocations, etc.

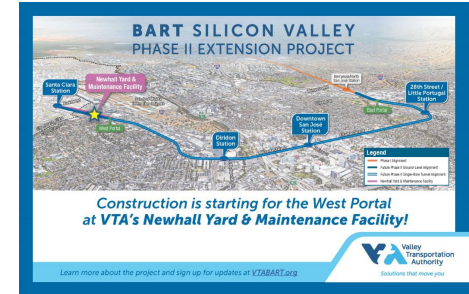

Physical Distribution

- Physical flyers are distributed to businesses/residences/etc. within a 1,000 ft. radius of the construction activity



Community Engagement

Matt Derby, VTA

2024 Tabling Engagement



Milpitas Station Pop-up – January 25th, 2024

Lunar New Year Festival – February 17th, 2024

Transit Day Meta – February 27th, 2024

VTA ACCESS Paratransit Open House –
February 29th, 2024

Biblioteca Latinoamericana Refresh –
March 9th, 2024

Spring Train Show – April 6th, 2024

5WUVP Open House – April 20th, 2024

Viva Calle SoFA – April 21st, 2024

4th Annual SCU PowWow – May 4th, 2024

1,413 total engagement interactions in 2024!

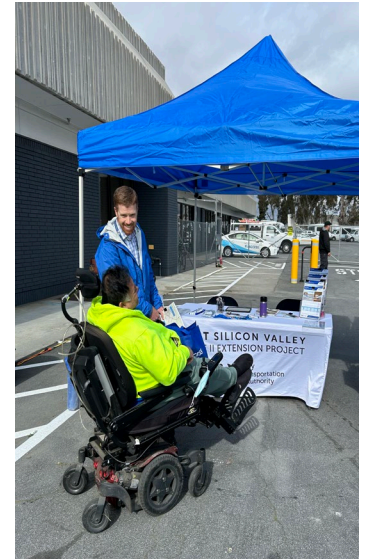
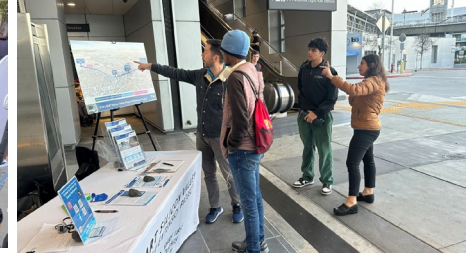

Upcoming Community Engagement



- **June 8, 2024:** East Bay Regional Connector Project Groundbreaking Event
- **June 8, 2024:** Dia de Portugal



New BSVII Project Website



- Phase 1 of new Project website set to launch in May
 - Will include webpages on transparency, the Project, a resource library, and FAQs
- Phase 2 of new Project website set to launch in June 2024
 - Will include webpages on construction, the Business Resource Program, and community activity
 - Will include an interactive construction map and Shop Local Marketing map to highlight small businesses

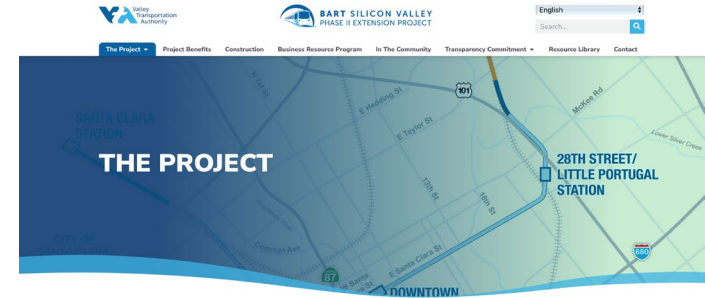

VTA's BSVII Project is a six-mile, four-station extension that will bring BART train service from the existing Berryessa/North San Jose through downtown San Jose to the City of Santa Clara. The BSVII Project includes an approximately five-mile tunnel which includes three underground stations (28th Street/Little Portugal, Downtown San Jose, and Diridon), one ground-level station (Santa Clara), as well as maintenance facilities.



Stations

28th Street/Little Portugal Station	Downtown San Jose Station	Diridon Station	Santa Clara Station
<p>The 28th Street/Little Portugal BART Station will be located between US 101 and 28th Street directly behind the Five Wounds Portuguese National Park. The station will include a plaza, bike parking, and onsite vehicle parking. Surrounding the station will be a shared-use path along 28th Street and other improvements for people who walk and bike to and from the station. The station area will be integrated with surrounding mixed-use development creating a distinct transit-oriented community (TOC).</p>			
6,700 Riders by 2040	1,200 Onsite Parking	Bicycle Parking	Close to Future Rapid Bus Service
Potential Transit-Oriented Development	Connected to Future Five Wounds Trail	Station Plaza	



Ongoing/Upcoming Activities Spring & Summer 2024

Start of Early Works
Construction at Newhall
Yard and Maintenance
Facility
Late April 2024



Business Resource Program
Launch
June 2024



Q2 2024

Q3 2024

**Subject to change*

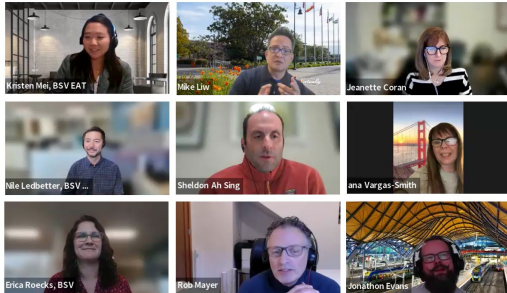

Design Review
Committees
Late Spring 2024

Online & Pop-Up Event
Community Engagement
Summer 2024



VTA's Official TBM Naming Contest



- Contest closed 4/29
- **Name Criteria:** Female name (or a representative name) that has significance to Santa Clara County.
- **732** names were submitted!!
- **Next Steps:** TBM Naming committee (made of BSV and City staff) will recommend name for General Manager to approve
- **Name Announced** next month



West Portal Groundbreaking Event



CWG Members invited!

YOU'RE INVITED!



Friday, June 14, 2024
10 AM – Noon

VTA's Newhall Yard
Entrance at 480 Brokaw Road,
Santa Clara, CA

Celebrate the start of construction for the project that will "ring the Bay" with fast, frequent, high-quality passenger rail service!



- **BRP Soft-Launch (Late-June 2024)**
 - BRP Section on the New Project Website and Social Media
 - BRP Canvassing Kit
 - Business Liaison Team
 - BRP Media Launch
 - Small Business Task Force
 - Businesses Community Workshop
- **Financial and Technical Assistance (Fall 2024)**
 - Community-Based Organization (CBO) Engagement
 - CBO Survey & Business Outreach Survey
 - Direct Financial Assistance (DFA) Program Launch (2025)

Opportunities for Project & Construction Updates



Interactive Efforts



Tabling events throughout the year around the station areas



Community Working Group meetings



Public Meetings



Community Group Meeting Outreach

- Reach out to have us present updates at your local Community Group/Neighborhood Association/etc. www.vta.org/about/subscribe

Resources



VTA's hotline number: **408-321-2345**

- Call to learn more about specific project efforts and provide your feedback



VTA's website: **vtabart.org**

Sign up to get alerted on nearby construction and find Informational Factsheets, Newsletters, and Blog Posts



Email questions to: **vtabart@vtabsv.com**

Social Media



Twitter: **[@vtabsv2](https://twitter.com/vtabsv2)**
Facebook: **[@vtabsv](https://www.facebook.com/vtabsv)**
Instagram: **[@vtabsv2](https://www.instagram.com/vtabsv2)**



CWG Member Report Out

Report Back – Santa Clara



- Alden Smith, Holland Partner Group
- **Ana Vargas-Smith**, *Reclaiming Our Downtown*
- David Cajigas, *Santa Clara University*
- Grace Davis, *SCU Service & Social Justice (SCCAP)*
- Jack Morash, *South Bay Historic Railroad Society*
- John Urban, *Newhall Neighborhood Association*
- Jonathon Evans, *Old Quad Residents Association*
- Ron Miller, *Bellarmino College Preparatory*
- Ryan Morfin, *San José Earthquakes*
- Todd Trekell, *Hunter Partners*
- *Vacant*, *Silicon Valley Central Chamber of Commerce*

How have you been sharing information and updates on BSVII with your community?

What have you heard from your communities?

Next Steps

- Next CWG meeting:
September 12th, 2024
 - Phase II Update
 - Early Construction Activities Update
 - Community Engagement
 - Station Area Planning & Adjacent Developments